

01-03 Trimming tool with tool round/round pillar guide for a 3.15 MN trimming crank press

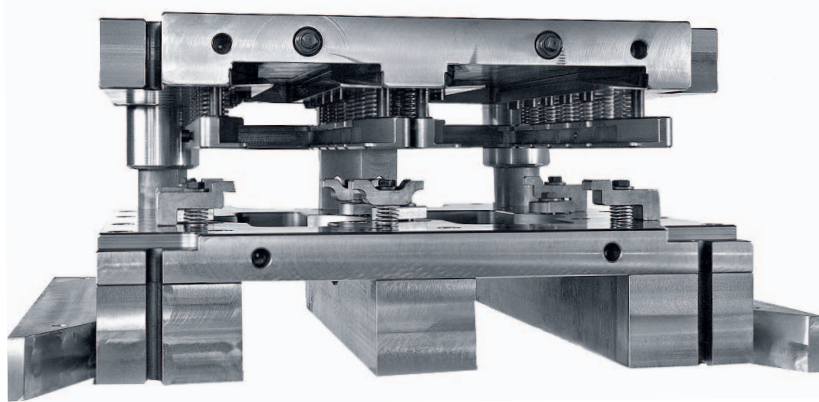

2-station cutting tool quick-change trimming tool with tool round/round pillar guide and mechanical releaser, trimming tool upper section in position "press ram in stroke centre" (view from front)

- 2 trimming stations for two-stage trimming, or for simultaneous, parallel trimming of two drop forgings.
- High trimming precision thanks to stable, oil-lubricated, low-wear tool round/round pillar guide with exchangeable, nitration-hardened steel guide elements (guide pillars and bushes).
- Quick changing of cutting tools thanks to upper trimming die quick-clamping system.
- Mechanical releaser.
- Automatic centring of the cutting tools.